

TECHNICAL DATA

Dimensions

Outside Dimensions (HxWxD)	15.98" x 70.86" x 12.52"
Packaging Dimensions (HxWxD)	18.9" x 73.22" x 14.76"
Net Weight	108 lbs
Gross Weight	99 lbs
Gross Volume (LTR)	132
40' HC Container Load (PCS)	168

Cooling

Refrigerant (Type/Gram)	R290/32
Cooling Method	Ventilated
Controller	Digital
Climate Class	4
Temperature Display	Yes
Temperature Controller	Digital
Temperature Range	32°F-53.6°F

Construction

Number of Pans	5* 1/2 GN Pans
Adjustable Shelves	No
Pan Materials	Stainless Steel
Length of Cord	88.58"
Insulation Material	C5H140
Internal Lighting	LED on top
LED Control Panel	Yes
Night Curtain	No
External Thermometer	Yes
Lock and Key	No
Feet / Adjustable feet	4* stable feet

Electrical

Voltage	110
Hz	60
Watt	180
Running AMPS	1.83



Intertek

COMPLIES WITH ANSI/NSF 7
FOR FOOD SERVICE

PLAN VIEW

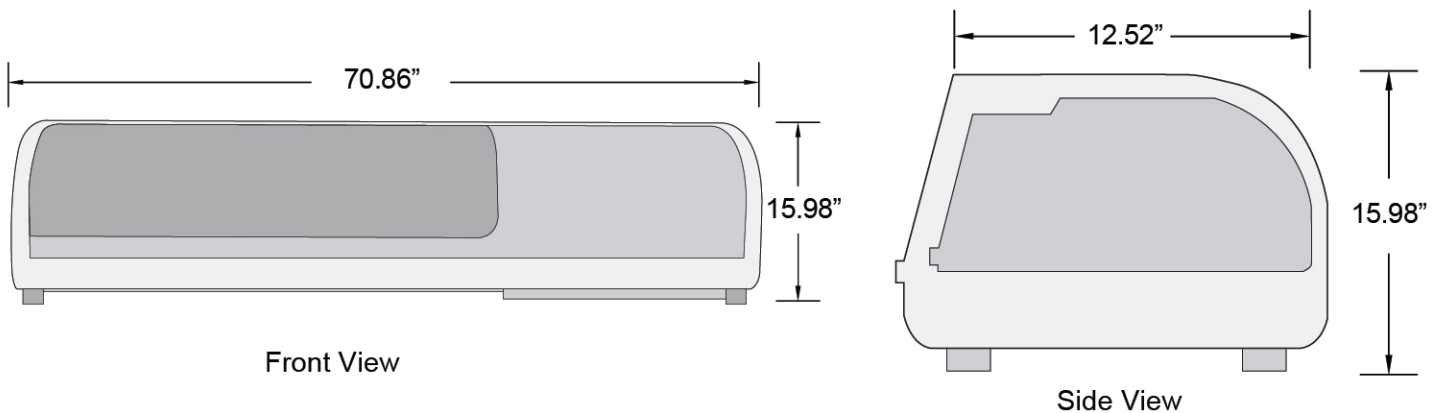

5* 1/2 GN Pans